

EZ-TILT-5000 / PLM

APPLICATION MANUAL

Ver. 4.xx -- 6.xx

Limited Warranty:

The seller warrants that its product will be free of defect in material and workmanship for a period of ninety (90) days from date of shipment thereof. Within the warranty period the seller will, at its option, either repair or replace such product which is determined by the seller to be defective and which is returned with shipping charges prepaid. This warranty will not apply to any product which has been subjected to misuse, negligence or accident; or misapplied; or modified or repaired by unauthorized persons; or improperly installed; or altered in any way. This warranty is not applicable to resale products.

THIS LIMITED WARRANTY IS IN LIEU OF AND EXCLUDES ALL OTHER WARRANTIES OR IMPLIED, INCLUDING THE WARRANTY OF MERCHANTABILITY OF FITNESS FOR PARTICULAR PURPOSE.

Company profile.

Advanced Orientation Systems, Inc. (AOSI) was founded in January of 1995 with a goal of developing and producing the next generation of tilt sensors. AOSI quickly became an integral part of the angle measurement industry.

AOSI's base line of Dual Axis tilt sensors are manufactured from a recently developed advanced Polymer. Inert to most chemicals and mechanically stable, this new material made it possible to manufacture dual axis miniature tilt sensors in the tens of thousands without any significant unit to unit structural deviation. These highly consistent sensors quickly became the logical, reliable and low cost replacement to brittle old style glass components. They found recognition in numerous medical, military, automotive and other high reliability applications.

The recent relocation to a new 2000sq. facility permitted AOSI to expand its R&D and manufacturing capabilities. Conveniently located in the Linden Industrial Business Center, minutes from Newark International Airport and just a few miles away from NEW YORK City allows AOSI easy access into the largest pool of industrial, engineering and personnel resources. Main engineering, R&D, production assembly and final testing are done in house, while some operations are subcontracted to ISO-9000 registered subcontractor facilities.

Total dedication to quality and reliability combined with aggressive research into process automation resulted in a very innovative production technique that guarantees consistent production of thousands of sensors per day with a staff of less than ten. Use of modern Electro-Mechanical CAD software assists engineers in all aspect of product and process development. Integrated fully equipped machine shop minimizes waiting for prototypes and production tooling. While in storage sensitive sensor parts are stored in a humidity and air free chamber. For repeatable and consistent electrical performance all sensors are filled by computer controlled filling stations capable of dividing 100 micro-liters into 4800 equal parts. Sensors testing is performed by ultra high resolution rotational angle positioning station by PARKER which is able to resolve and verify angles With HEIDENHEIM encoder to a sub-arcsec level.

To tap into new markets requiring high resolution and extended Military temperature range AOSI had embarked on a mission to develop a line of ultra linear single axis tilt sensors utilizing high reliability engineering ceramics and advanced metal deposition techniques. Wide range sensors are able to accurately measure angles in excess of +-70 arcdeg, while high resolution versions are successful in detecting 2 micro radian (0.5 arcsec) angular deviations.

AOSI had noticed that the major deterrent from using electrolytic tilt sensors was and is the difficulty of electronic interfacing and signal processing. To solve this dilemma AOSI had expanded it expertise from sensor development to microprocessor and analog circuit design and sensor interfacing. This step had diversified AOSI's activities from being a component manufacturer into a System Integrator. Some apparent examples of this step are the EZ-COMPASS and EZ-ALARM modules. Both products utilize customized advanced microcontrollers and mixed signal circuitry. Internally developed dynamic algorithms are performing all required sensor interfacing and signal processing. Both products available in single and OEM quantities. Custom product development and licensing are available on individually approved basis.

Market research, strong technical background and dynamic character of AOSI's marketing and technical teams led the company release and market in average one new product every two month. AOSI's strong dedication to quality, in-process inspection and advanced testing capabilities let us provide customers with flawless and reliable products.

New Polymer based electrolytic tilt sensors offer users a powerful combination of benefits. Structural consistency, reduced size, low profile, PCB mounting and solderability are very important qualifying factors. High volume applications such as Auto-Alarms, VR HMDs, wheel alignment, military and medical devices greatly benefit from unsurpassed consistency in sensors' performance. Newly formulated advanced materials combined with the custom developed electronic packages, provide the user with new and reliable methods for computing and accurately finding angles quickly in a cost effective way.

For any additional press release or other company information all questions should be directed to Mr. Marty Berger / Vice President Of Marketing. **e-mail:** sales@aositilt.com **site:** www.aositilt.com

EZ-TILT-5000

EZ-TILT-5000, advanced programmable dual/single axis LINEAR Analog/Digital output tilt module, built around a customized state of the art CMOS Microprocessor. A 2"x 2" assembled PCB provides concurrent Analog, PWM and RS-232 inclination information in two axis of tilt. The module is fully temperature compensated for NULL and GAIN. The module is equipped with full range linearity correction routine for each axis of tilt and two software adjustable threshold detectors, one for each axis.

The module uses any two sensor combination of either SX-xxxD-LIN, SX-003D-NULL, SX-xxxD-VIB or SX-COMBO single axis inclination sensors and provides an economical and reliable tilt sensing solution for applications requiring superior Nulling capabilities with concurrent excellent Mid-Wide range LINEARITY, resolution, repeatability and symmetry. Rugged hermetic construction and MIL-SPEC temperature range make these sensors perfectly suitable for numerous high precision OEM, military, medical, optical, automotive, range finder, alignment, automation, robotics and construction angle measurement applications.

The EZ-TILT-5000 also includes two fully programmable level threshold detector lines that allow the user to set level sensitive alarms for pitch and roll. Innovative design, four set screw holes and small size facilitate uncomplicated mounting. The system can be easily supplied with two different tilt sensors. This rare option lets users solve special applications when one axis requires high tilt range while the other one requires high resolution. Sensors could be remotely located and calibrated to different ranges if so required.

Both Analog and PWM outputs are fully software programmable and are updated each read cycle for each enabled axis. The analog output range is top limited by 4Vdc and bottom limited by 1Vdc for the full set angular range. The PWM will output 10% to 90% duty cycle for the set angular range at base frequency of 37Hz.

Exceptionally stable and consistent performance in temperature variable environments and it's LOW cost make EZ-TILT-5000 the perfect choice for high accuracy leveling applications. In addition to digital filtering the electrolyte may be modified to mechanically filter out errors induced by shock & vibration. Test data could be supplied on 3.5" disk upon special request.

The module is able to operate in a stand-alone mode with a 4 line x 20 character serial LCD display. The wide range model could operate to +-85 arcdeg covering a total span of 170 arcdeg. The module is also available on 0.9" x 3.0" PCB for angle measurements in bore hole, tunneling, logging and oil drilling applications.

All commands are case sensitive. All commands must end with <CR>. The user MUST type save<CR> after each setting command. It is also recommended to soft reboot with ax<CR> command.

ACTION COMMANDS:

“ax”	-	reboot. Must be done after each “save” command.
“h”	-	halts re-entry from LCD or “go”/continuous modes.
“go”	-	start continuous output. Period, averaging and sensors must be set prior to issuing this command.

SETTING COMMANDS:

	must type	save<CR> to save settings. Defaults in Parenthesis
“sdo=l”		set LCD mode for the next powerup (t)
“sdo=t”		set STD mode for the next powerup (t)
“ave=[1...255]”		set averaging, numbers 1...255 are valid. (255)
“b=[1-7]”		set baud rate (1=300, 2=1200, 3=2400, 4=4800, 5=9600, 6=19200, 7=38400) (6)
“period=[1 .. 255]”		set delay between scans for “go” command in system ticks. 1 tick ~ 10msec, e.g. max is “period=255” ~ 2.6 sec (100)
“e=[sensor letter] = [d=disable, e=enable]”		enable or disable sensor printout for “go” and “s?” commands
examples:		“ep = e” – enable pitch, “er = d” – disable roll, etc... “et=e” - enable temperature, “eg=e” – enable grade mode
“maxroll=[angle]”		set the maximum Roll angle in order to limit the analog output swing for Vmax=4Vdc, Vmin=1Vdc.
“maxpitch=[angle]”		set the maximum Pitch angle in order to limit the analog output swing for Vmax=4Vdc, Vmin=1Vdc.
“round=[0-4]”		set decimal display resolution for both PC and LCD modes (3)
“lcd=[1 st string]”		set top line to be shown on LCD (nothing)
“lcd1=[2 nd string]”		set second line to be shown on LCD (nothing)
“eg=[e] or [d]”		enable or disable %GRADE mode output of tilt (d)
gt=[number]		set the coefficient for the temp sensor (0.12210)
ft=[number]		set switching temperature for comp. coefficients (0)
"tc roll=[number]"		set positive SF compensation coefficient for roll (0.0008)
"tc pitch=[number]"		set positive SF compensation coefficient for pitch (0.0008)
"ntc roll=[number]"		set negative SF compensation coefficient for roll (0.005)
"ntc pitch=[number]"		set negative SF compensation coefficient for pitch (0.005)
“drift roll=[number]”		set Null drift coefficient for roll positive temp (0.00000)
“drift pitch=[number]”		set Null drift coefficient for pitch positive temp (0.00000)
“ndr roll=[number]”		set Null drift coefficient for roll negative temp (0.00000)
“ndr pitch=[number]”		set Null drift coefficient for pitch negative temp (0.00000)
“trip pitch=[number]”		set absolute angular threshold value for pitch (max angle)
“trip roll=[number]”		set absolute angular threshold value for roll (max angle)
“calib pitch”		start linear calibration for pitch axis (see procedure)
“calib roll”		start linear calibration for roll axis (see procedure)
“lin r=[e/d]”		e=enable or d=disable linear correction for roll (d)
“lin p=[e/d]”		e=enable or d=disable linear correction for pitch (d)
“cont=[e/d]”		e=enable or d=disable continuous output on powerup (d)
“echo=[e/d]”		e=enable or d=disable local character echo printing (d)
“iir=[e/d]”		IIR filter for fast output e=on, d=off (d)

QUERY COMMANDS: must end with <CR> .

“ave?”	print average
“b?”	print baud rate
“help”	print all available commands
“period?”	print delay between scans
“s?”	print single scan in degrees or %grade
“p?”	print pitch angle in degrees or %grade
“r?”	print roll angle in degrees or %grade
“maxroll?”	print roll max angle setting that matches 1 to 4Vdc span
“maxpitch?”	print pitch max angle setting that matches 1 to 4Vdc span
“round?”	print decimal resolution
“lcd?”	print 1 st LCD line
“lcd1?”	print 2 nd LCD line
“t?”	print temperature in degC
“tc roll?”	print thermal SF compensation coeff for positive roll
“tc pitch?”	print thermal SF compensation coeff for positive pitch
“ntc roll?”	print thermal SF compensation coeff for negative roll
“ntc pitch?”	print thermal SF compensation coeff for negative pitch
“drift roll?”	print Null drift coefficient for Roll
“drift pitch?”	print Null drift coefficient for Pitch
“\$TNHCQ,XDR”	print sensors output in NMEA-0183 XDR sentence
“trip roll?”	print roll threshold angular value
“trip pitch?”	print pitch threshold angular value
“ver?”	print version designator of the installed software
“drill?”	print total combined angle in degrees
“delta?”	print (roll angle – pitch angle)
“coef?”	print all operational coefficients
“gt?”	print temperature coefficient

NOTE that: In GRADE mode all reply strings include “g” in front of the data designator to advise the user that the value is in %grade.

Both “maxroll” and “maxpitch” commands are required to be set prior to using the analog or PWM modes. Without maxroll and maxpitch commands set, the analog and PWM outputs may be erroneous. Initial sensor installation errors are corrected with offset setting.

FOR LCD USERS: To move from LCD to PC, remove NULL modem, plug module into the PC after HYPER TERMINAL software is running. After the user sees continuous printing of numbers on the screen the user should press “h”<CR>. The printing will stop.

To change to PC mode the user should type “sdo=t”<CR> and then “save”<CR>. Now the unit is ready to operate in PC mode.

To change from PC mode the user while in PC mode should type “sdo=l”<CR> and then “save”<CR>. Now the unit is ready to operate in LCD mode. Remove the serial cable from the PC, add a NULL modem adapter and plug into the LCD. On next power-up the unit will start in LCD mode.

Single Module Wiring diagrams:

JP3: 6 pin connector “main analog port”

<u>PIN</u>	<u>FUNCTION</u>	<u>COLOR WIRE</u>
1	PITCH PWM out	Beige
2	ROLL PWM out	Brown
3	ROLL Vdc out	White
4	PITCH Vdc out	Pink
5	ROLL Vdc alarm out	Orange
6	PITCH Vdc alarm out	Grey

JP2: 6 pin connector “power / interface RS232 port”

<u>PIN</u>	<u>FUNCTION</u>	<u>COLOR WIRE</u>
1	TX out (square pad)	Blue
2	RX in	Green
3	6 to 12 Vdc supply	Red
4	GND	Black
5	GND	Yellow
6	5Vdc out (reference only) or 5Vdc supply	Purple

JP1: 6 pin connector “remote sensors port”

<u>PIN</u>	<u>FUNCTION</u>
1	pitch 1 sensor white wire
2	pitch 2 sensor red wire
3	pitch 3 sensor blue wire
4	roll 1 sensor white wire
5	roll 2 sensor red wire
6	roll 3 sensor blue wire

Standard RS232 / LCD cable wiring:

<u>BOARD JP2:</u>	<u>25D CONNECTOR</u>	<u>9 PIN / LCD</u>
PIN 1	PIN 3	PIN 2 / 3
PIN 2	PIN 2	PIN 3 / 2
GND	PIN 7 and BATTERY GND	PIN 5 and BATTERY GND

TURCK cable wiring for ABS enclosures:

RED	--	6—12 Vdc power
BLACK	--	GND common
BLUE	--	TX
WHITE	--	RX

4-20 mA type UPGRADE OPTION

The 4-20 mA upgrade operates independent from the RS232. Upon supply of voltage - 24 Vdc at pin one (1) of JP1 on the upgrade board, the system will immediately output current into 500ohm loads on both output pins. The upgrade board internally generates supply for the main EZ-TILT-5000 module.

4-20 mA type wiring

- a. cable with two red connectors for inter-board communication

FOUR PINS on the 4-20 mA type upgrade board

PIN 1	Voltage IN	(24 Vdc)
PIN 2	ROLL OUT	(into 1000 ohm load)
PIN 3	PITCH OUT	(into 1000 ohm load)
PIN 4	GND	(common to all signals)

**All NEW units are delivered Calibrated in the factory. No additional calibration is required !
PERFORM THE FOLLOWING ONLY IF CHANGING OR REPLACING TILT SENSORS.**

MAIN calibration for multi-sensor systems.

FOR SYSTEMS THAT HAVE NEW SENSORS INSTALLED IN THE FIELD AND WERE NEVER CALIBRATED RERFORM THE UNDERLINED SECTION FIRST:

Power-up the module. Hold the *Ctrl* key “a” and type “debug” <CR>. Hold the *Ctrl* key and press “a” key. After that you are required to type “kill” <CR> This will erase all previous calibration parameters. Turn the unit off for 3 seconds after the new header is displayed.

Power-up the module. Hold the *Ctrl* “a” key and type “debug” <CR>. Then type: “T=22” <CR>

“save”<CR> then type “ax”<CR>

MAIN CALIBRATION MODE

Power-up the module. Then type: “T=22” <CR>“save”<CR>

Hold the *Ctrl* “a” key and type “debug” <CR>.

Now you are required to hold the *Ctrl* key and press “a” key. After that you have to type “LevelCal” <CR> with L and C capitals.

Press <CR> to answer first two questions and “y” for room temperature calibration. This will display “calibrate roll”.

Answer with “y” and observe the numbers on the screen. Move the corresponding sensor until the displayed numbers are near or are 0. When stop for a second or two and press <CR>.

Now the unit will ask you to move the sensor to the maximum angle. When you reached stable positive value press <CR>. Type in the actual angle value that the sensors is positioned at.

Repeat same procedure for the **pitch** axis.

Press <CR> to all other questions till you are out of the calibration mode. Type save<CR>

Housing installation procedure:

To install the system you are required to place it flat on a surface and try to level the surface to near null reading in both axis.

Locate the position where you want to install the housing. Remove the cover and secure the housing to the surface with one screw.

Tilt the surface one to two degrees and observe the output of the module on the screen with a go<CR> command in Hyper terminal mode. Try to pivot (slightly rotate) the housing until one of the outputs (cross axis) is equal zero.

Secure the housing with the second (third and fourth) screws and close the cover. At this time the module is properly setup for minimum cross axis tilt error.

LINEAR CORRECTION OPTION.

EZ-TILT-5000 includes independent dynamic non-restrictive linear correction. The user has an option to linearize one or both axis in whole or in any selected region of the output. The decision to activate the linearization option should be done after the axis was tested in its full range and the non-linear region is clearly defined.

Roll axis calibration

1. Move the sensor to the maximum angle.
2. Type "calib roll"<CR>
3. The system will reply with number of available points and wait for manual input of the present angle. Type the value of the angle and press <CR>
4. The system will display the acquired angular value along with its manually read equivalent. System will also display the number of remaining points available for input.
5. Move the sensor to the next angular position. After stopping wait a few seconds, type the value of the angle and press <CR>
6. The system will display the acquired angular value along with its manually read equivalent. System will also display the number of remaining points available for input.
7. Continue steps 5 and 6 till the total desired tilt range is completed.
8. To terminate data input press <CR> without typing any numerical data.
9. The system will print all points in numerical order for your review.
10. Type "save"<CR> to save the data.. Please note that you can perform data input as many times as you feel required. Each time "calib roll"<CR> is performed the old data is erased.
11. Type "ave=255"<CR> then "lin r=e"<CR> and "save"<CR> to activate and save linear correction

In case two axis are used, perform the above calibration for the second axis. You will be required to use same commands, but all references to "roll" or "r" should be replaced by "pitch" or "p".

General start-up instructions via Hyper terminal.

1. Every Windows based PC has a Hyper terminal program, which could be found in the Accessory section.
2. Select the hyper terminal and open it for "direct com1" communication. If your computer has free com2, then open the hyper terminal in com2.
3. Make sure that the terminal settings are: 19200 baud, 8 bit, no parity, 1 stop, no flow control.
4. After the terminal is opened, the computer is ready to communicate with the module.
5. Plug the DB9 connector into the appropriate port in the PC, and then plug the blue connector to the main connector port on the module.
6. After both connectors are secured, turn the POWER ON.
7. Immediately after the power is applied, the unit will send a start header to the PC. The user will see the header displayed on the screen.
8. At this stage the module is ready to accept direct commands from the user.

Troubleshooting:

1. No Header is displayed.

Check the cable. Make sure that Rx and Tx are wired properly. Make sure there is common ground between the PC, Power Supply and the module. If necessary, swap Rx and Tx. Check battery.

2. Strange characters are displayed.

This response is typical when there is a mismatch in baud rate. Change Hyper terminal to new baud rate, and restart Hyper terminal with the new setting.

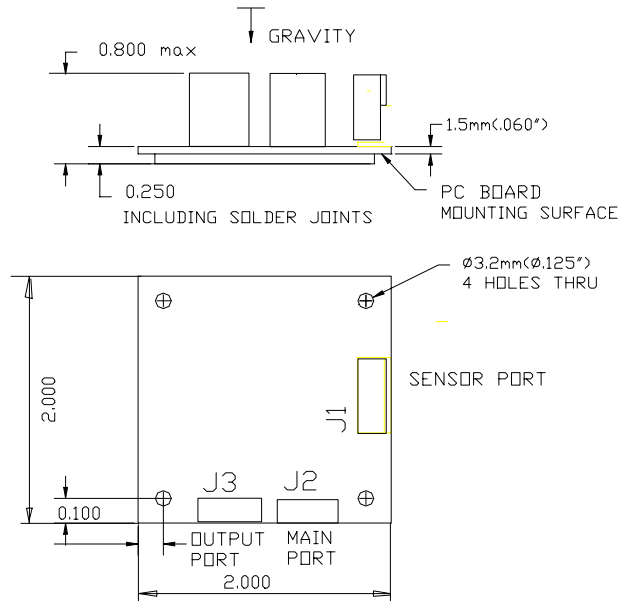

CALIBRATION RESULTS:

Product version: _____ Unit serial number _____

Pitch sensor: _____ Roll sensor: _____

CUSTOM: _____

Performed verification angles: NULL, + _____ arcdeg, - _____ arcdeg on each axis.

Reviewed: _____ Date: _____

All STD units are set to 19200 baud for Hyper terminal use at 19200,8,1,N,no flow control

Board envelop dimensions without sensors are: 2" x 2" x 0.8" (L:W:H) with 4 mounting holes 1/8" diam each, symmetrically located at all corners, spaced 1.8" center hole to center hole.

Models with software version of 3.1xx and earlier do not require ctrl A debug to be typed before entering T or calibration mode.